

# SMC Control Algorithm Based DSTATCOM for Power Quality Improvement

<sup>1</sup>Abhay P. Bhavsar, <sup>2</sup>Darshan Vora, <sup>3</sup>Ankitsingh Basera

<sup>1</sup>PG Student, Electrical Department, CGPIT, Uka Tarsadia University, Surat, Gujarat

<sup>2,3</sup> Assistant Professor, Electrical Department, CGPIT, Uka Tarsadia University, Surat, Gujarat

---

**Abstract:** This paper presents the SMC (Sliding Mode Control) With Proportional-Integral (PI) controller which is used for DSTATCOM for improving current induced power quality issues. The advantages of using SMC for regulating the DC link voltage of DSTATCOM are reduction in number of sensors for estimating reference currents and the stability of DC link voltage during transient condition. The use of PI controller for terminal voltage gives the error free voltage regulation in steady state conditions. The voltage regulation feature of DSTATCOM offers various advantages such as single point voltage operations with the reactive power compensation, harmonic currents mitigation, and stable DC link voltage. The SMC algorithm is successfully implemented on a DSTATCOM employed with three phase loads. The performance of the proposed control algorithm is found satisfactory for voltage regulation and mitigation of power quality problems like reactive power compensation, harmonics elimination under nonlinear/linear loads. These schemes are simulated under MATLAB using SIMULINK and Sim Power System (SPS) toolboxes. Simulation and experimental results demonstrate the performance of these schemes for the control of DSTATCOM.

**Keywords:** DSTATCOM (Distribution Static Compensator), control algorithm, power quality, Reactive power compensation, power control.

---

## I. INTRODUCTION

In this paper SMC with PI control algorithm is used for control of the dynamic operation of the DSTATCOM which improves the power quality [1]. The control algorithms for the operation of DSTATCOM such as synchronous reference frame theory, instantaneous reactive power theory, Icos  $\emptyset$  algorithm, Adeline algorithm and notch filter based algorithm use sensed load currents for estimating the supply currents [2-4]. The main advantage of using SMC is that the reference supply currents are estimated from the DC link voltage of Voltage Source Converter (VSC) which gives the robust control during transient conditions [5]. The DC link voltage of VSC used as DSTATCOM is regulated by SMC which suppresses undershoots and overshoots in DC link voltage [1]. Power transmission due to reactive power unbalances, the problems like voltage deviation during load changes and power transfer limitation were observed. AC loads are most of consuming reactive power due reactance [6]. Along with this problem, the use of non-linear loads like compact fluorescent lamps, television, computers, and battery chargers injects harmonics into the system [7] affects other connected loads.

## II. CONFIGURATION OF DSTATCOM

The Distributed Static Compensator (DSTATCOM) is used in distribution system for reactive power compensation and reduce harmonics. Figure 1 shows the schematic diagram of VSC based DSTATCOM in distributed generating system.

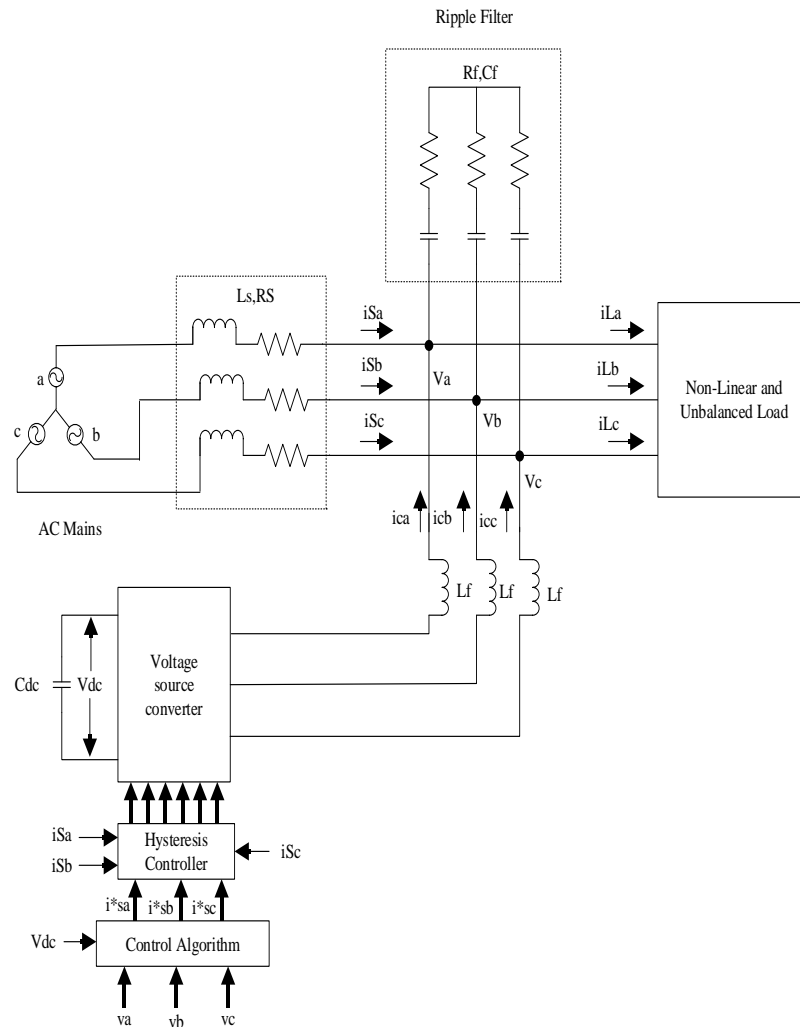

**Figure 1: Schematic diagram of VSC based DSTATCOM**

DSTATCOM is connected parallel with the load and an AC mains at the point of common coupling (PCC) for improving power quality [1]. The gate pulses for VSC of DSTATCOM

Generated by hysteresis controller. The control algorithm gives the reference current. For improving power quality the DC link voltage and its capacitor of DSTATCOM are selected depending on PCC voltage and rating of the load. The DC link voltage is estimated as

$$V_{dc} = \frac{(2\sqrt{2}(V_L/\sqrt{3}))}{m_a} \quad (1)$$

Where,  $V_L$  is the line voltage at PCC,  $m_a$  is the modulation index and its maximum value is 1.

To mitigate the ripples in the compensating currents the interfacing inductors are used. The value of inductor can be calculated as

$$L_f = \frac{(\sqrt{3}/2)m_a v_{dc}}{6a f_s I_{cr,pp}} \quad (2)$$

Where,  $v_{dc}$  is the DC bus voltage,  $m_a$  is the modulation index,  $f_s$  is the switching frequency,  $I_{cr,pp}$  is the ripple current through inductor,  $a$  = overloading factor.

Due to switching of insulated gate bipolar transistors (IGBT) of VAC a ripple filter is made with resistors and capacitors for filtering the switching noise at PCC.

### III. CONTROL ALGORITHM

SMC with PI controller-based algorithm used for control of three phase VSC-based DSTATCOM Shown in Figure 2.

The advantages of SMC with PI controller are as follows:

1. The load current sensors can be eliminated with the use of SMC in the control of DC link voltage which make the DSTATCOM cost effective.
2. SMC gives the robust control during transient conditions and the fast dynamic response in terms of overshoot and undershoot of DC-link voltage of VSC during load variation/transient condition.
3. The use of PI controller in terminal voltage regulation gives the zero-voltage regulation during steady-state condition.

The disadvantage of SMC is steady state error. SMC tracks the reference very robustly but with a small steady-state error.

For meeting the load active power and losses in the DSTATCOM SMC gives in-phase component current. PI controller gives the quadrature component current for regulating the terminal voltage. The SMC control algorithm [8-13] detects the deviation from the reference trajectory and promptly changes the switching control strategy to follow the reference trajectory.

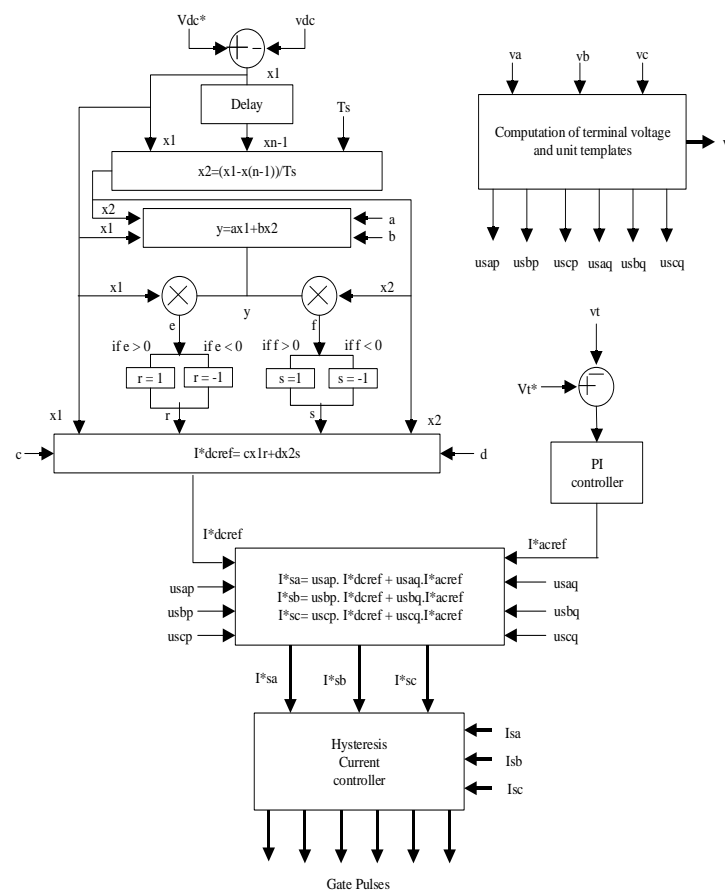

Figure 2: Control Algorithm of DSTATCOM using SMC with PI controller

The in-phase components of unit vectors are estimated from the PCC voltages ( $v_a, v_b, v_c$ ) [1].

The instantaneous amplitude of PCC is estimated as

$$V_t = \sqrt{2(v_a^2 + v_b^2 + v_c^2)}/3 \quad (3)$$

The in-phase components of unit templates are

$$u_{sap} = \frac{v_a}{V_t}, \quad u_{sbp} = \frac{v_b}{V_t}, \quad u_{scp} = \frac{v_c}{V_t}; \quad (4)$$

The quadrature components of unit templates are

$$u_{saq} = \frac{(-u_{sbp} + u_{scp})}{\sqrt{3}} \quad (5)$$

$$u_{sbq} = \frac{(u_{sap}\sqrt{3} + u_{sbp} - u_{scp})}{2} \quad (6)$$

$$u_{scq} = \frac{(-u_{sap}\sqrt{3} + u_{sbp} - u_{scp})}{2} \quad (7)$$

The amplitudes of in-phase references currents are estimated from DC link voltage. The sensed DC voltage ( $v_{dc}$ ) is filtered using a low pass filter and compared with the reference voltage ( $v_{dc}^*$ ) to generate the error signal,  $x_1$  as

$$x_1 = v_{dc}^* - v_{dc} \quad (8)$$

Derivative of equation

$$x_2 = \dot{x}_1 = \frac{1}{T} \{x_1 - x_{(n-1)}\} \quad (9)$$

Where  $x_1, x_2$  are the state variables,  $x_{(n-1)}$  is the previous sample value, and  $T$  is the sampling time.

The switching parameters  $r$  and  $s$  are selected according to the slope of the DC link voltage error.

$$r = +1 \text{ if } yx_1 > 0, \quad r = -1 \text{ if } yx_1 < 0$$

$$s = +1 \text{ if } yx_2 > 0, \quad s = -1 \text{ if } yx_2 < 0 \quad (10)$$

Where  $y$  is the switching hyper plane function.

$$y = ax_1 + bx_2 \quad (11)$$

The amplitudes of reference active source currents are found as

$$I_{dcref}^* = cx_1r + dx_2s \quad (12)$$

Where  $a, b, c, d$  are the constants of the SMC.

The estimated amplitude of the reference source current is multiplied with the in-phase unit templates to generate the active power component of reference source currents as

$$i_{sap}^* = I_{dcref}^* u_{sap}, \quad (13)$$

$$i_{sbp}^* = I_{dcref}^* u_{sbp}, \quad (14)$$

$$i_{scp}^* = I_{dcref}^* u_{scp} \quad (15)$$

The amplitude of quadrature component ( $I_{acref}^*$ ) is computed using PI controller, taking the Difference of reference AC voltage ( $V_t^*$ ) and the calculated amplitude of PCC voltage ( $V_t$ ) as

$$v_{ace} = V_t^* - V_t \quad (16)$$

The output of PI controller for maintaining terminal voltage at reference value is given as

$$I_{acref}^*(k) = I_{acref}^*(k-1) + K_{pa} \{v_{ace}(k) + v_{ace}(k-1)\} + K_{ia} v_{ace}(k) \quad (17)$$

Where,  $K_{pa}$ ,  $K_{ia}$  are the PI gains of the PI controller, respectively.

$v_{acc}(k)$  and  $v_{acc}(k-1)$  are the voltage errors at the  $k$ th and  $(k - 1)$ th instants, respectively.

The output of PI controller ( $I_{acref}^*$ ) is multiplied with the quadrature unit templates to Generate the reference quadrature source currents for regulating terminal voltage.

$$i_{saq}^* = I_{acref}^* u_{saq}, \quad (18)$$

$$i_{sbq}^* = I_{acref}^* u_{sbq}, \quad (19)$$

$$i_{scq}^* = I_{acref}^* u_{scq} \quad (20)$$

The total reference source currents can be calculated by adding both quadrature reference Currents ( $i_{saq}^*$ ,  $i_{sbq}^*$ ,  $i_{scq}^*$ ) and the in-phase reference currents ( $i_{spa}^*$ ,  $i_{spb}^*$ ,  $i_{spc}^*$ )

$$i_{sa}^* = i_{sap}^* + i_{saq}^*, \quad (21)$$

$$i_{sb}^* = i_{sbp}^* + i_{sbq}^*, \quad (22)$$

$$i_{sc}^* = i_{scp}^* + i_{scq}^*, \quad (23)$$

The source currents ( $i_{sa}$ ,  $i_{sb}$ ,  $i_{sc}$ ) are compared with these estimated reference source currents ( $i_{sa}^*$ ,  $i_{sb}^*$ ,  $i_{sc}^*$ ) and the current error signals are given to the hysteresis current controller and the gating pulses are generated for the three legs of VSC used as DSTATCOM.

#### IV. SIMULATION RESULTS AND DISCUSSION

The section discusses the performance of three-phase SMC based control algorithm for three-phase DSTATCOM is simulated using MATLAB SIMULINK and Sim Power System (SPS) toolboxes at distribution level linear and nonlinear loads. The performance of control algorithm is observed for time varying linear and nonlinear loads.

##### A. Performance of the system without DSTATCOM

A diode based rectifier as a nonlinear load is connected to the supply system. The waveform of phase 'a,b,c' voltage at PCC ( $V_{sa}$ ), source current ( $I_{sa}$ ) and load current ( $I_{la}$ ) are shown in figure 3 and 4. Total harmonic distortion (THD) of source current is found 17.04%. The waveforms distortion shows that nonlinearity of load can affect the PCC voltage and source current.

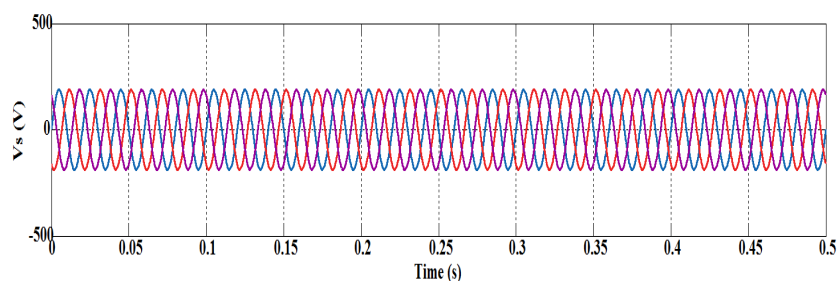
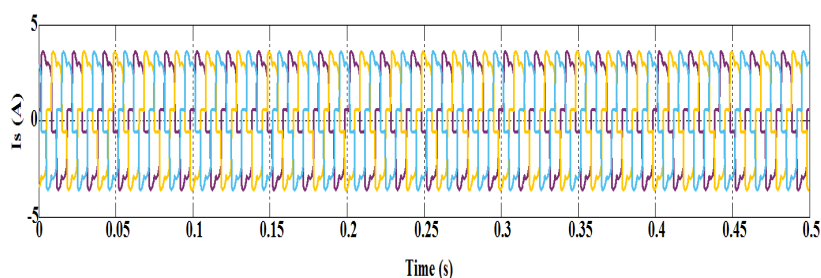
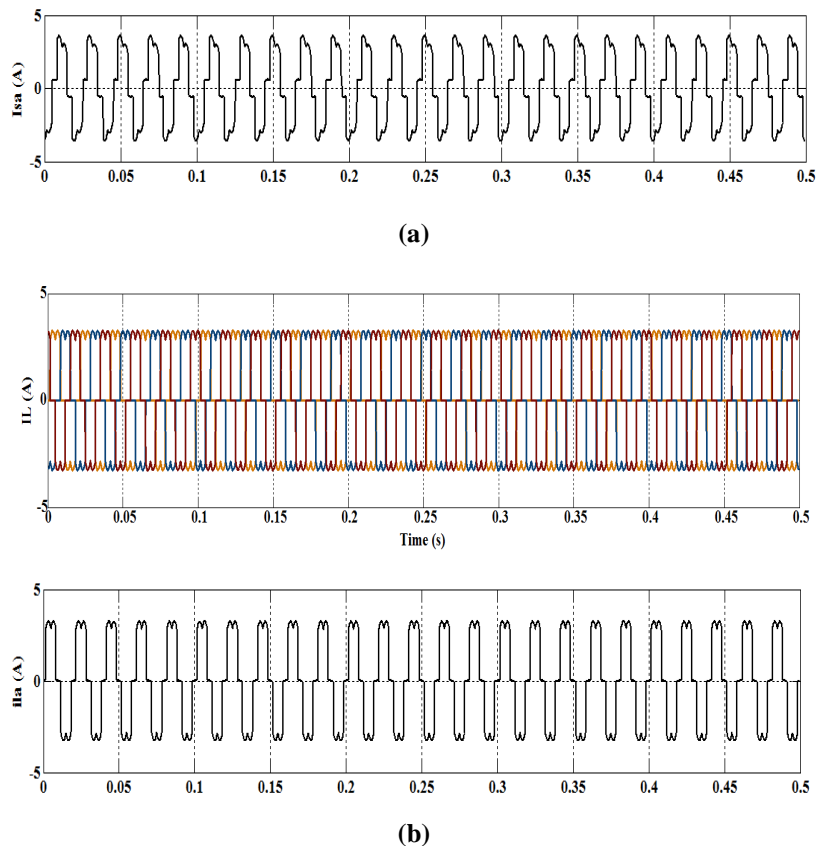

Figure 3: Waveform of PCC voltage without DSTATCOM

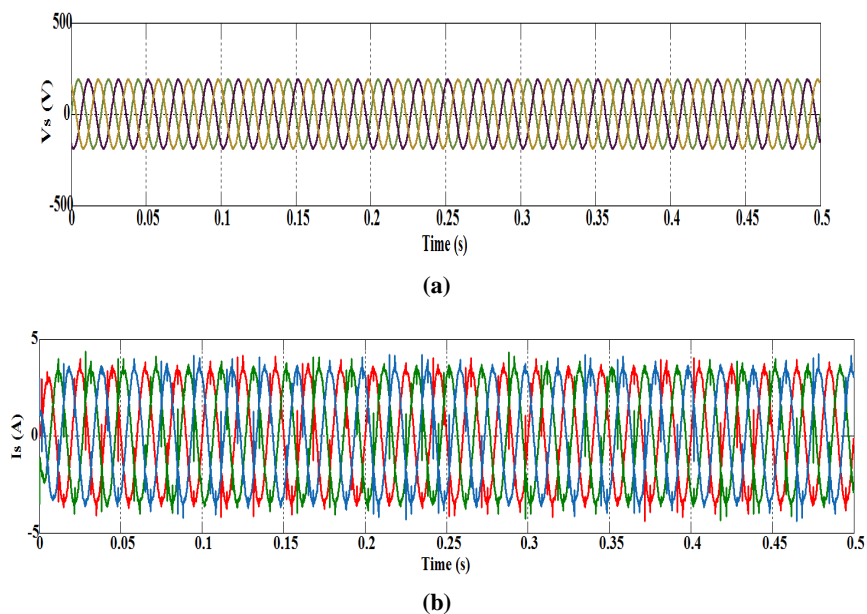



**Figure 4: Waveform of (a) Source current of phase 'a' (b) Load current of phase 'a'**

### B. Performance of the system with DSTATCOM

A diode based rectifier as a nonlinear load is connected to the supply system. The waveform of phase 'a' voltage at PCC ( $V_{sa}$ ), source current ( $I_{sa}$ ), load current ( $I_{la}$ ) and compensating current ( $I_{ca}$ ), are shown in figure 5. Total harmonic distortion (THD) of phase 'a' at source current is found 4.92%. It shows the functions of DSTATCOM and its control algorithm for load balancing, harmonic compensation and reactive power compensation.



**Figure 5: Waveform of (a) PCC voltage with DSTATCOM (b) Source current with DSTATCOM**

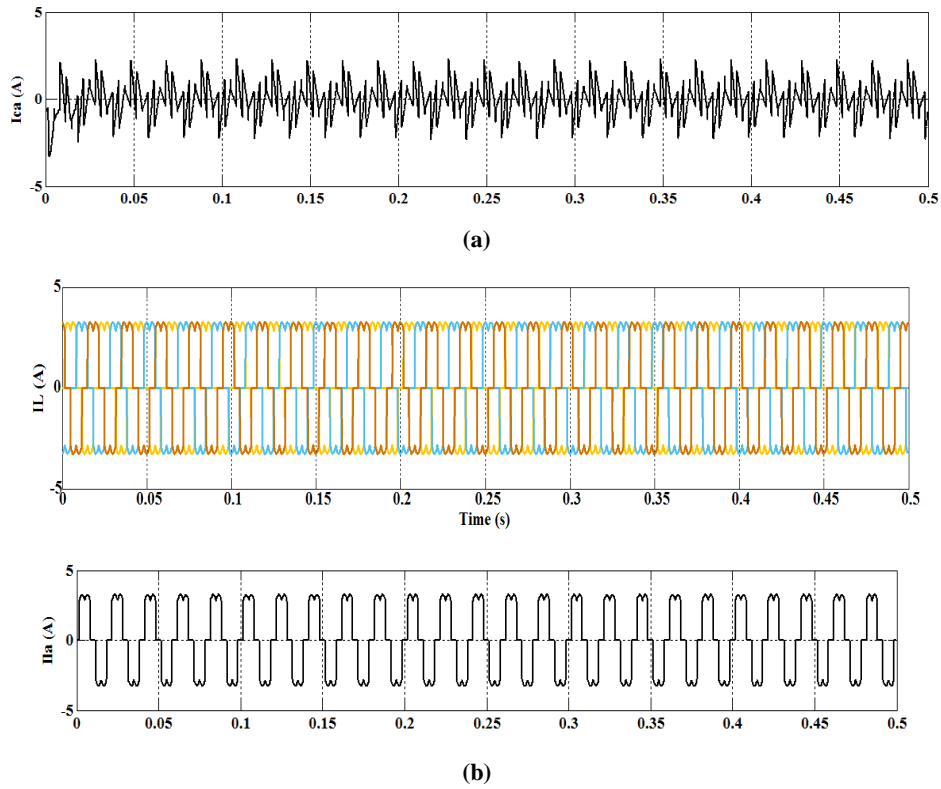

Figure 6: Waveform of (a) Compensating current of phase 'a' (b) Load current of phase 'a'

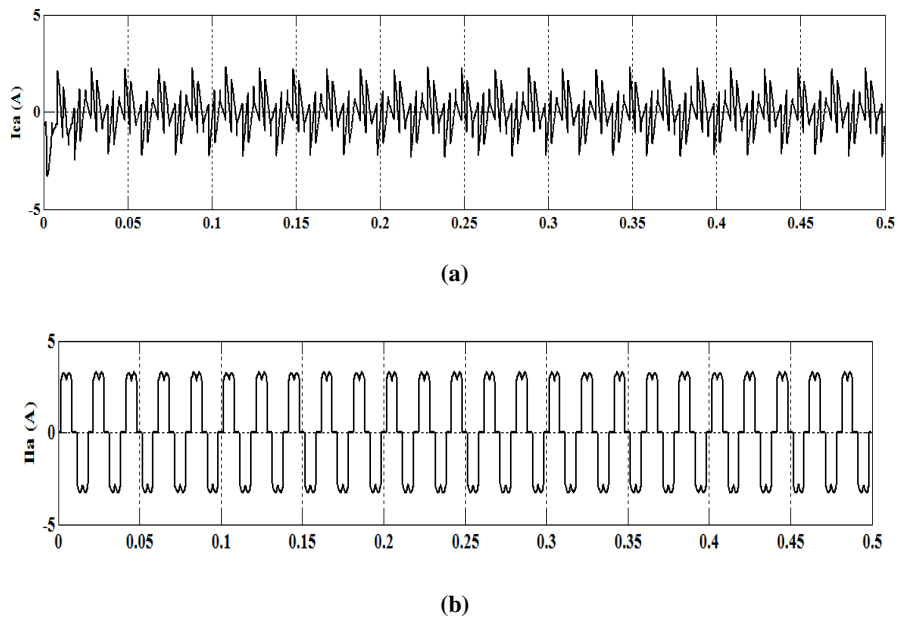

Figure 7: Waveforms of (a) compensating current of phase 'a' (b) load current of phase 'a'

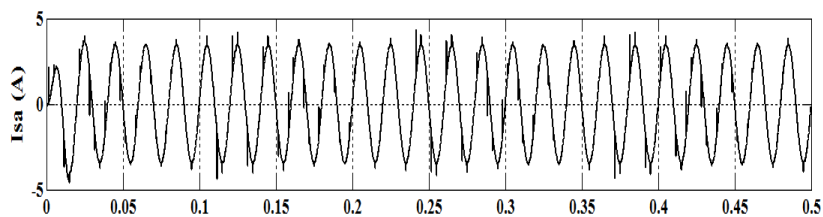

Figure 8: Improving source current

In figure 7 (a) shows the compensating current which can generate by the DSTATCOM this compensating current add with load current and make source current sinusoidal shown in figure 8.

Figure 9 shows the Inverter capacitor voltage, the inverter capacitor voltage is maintained the constant dc 387 voltage because of steady state error. It shows the satisfactory performance of the DSTATCOM and SMC control algorithm.

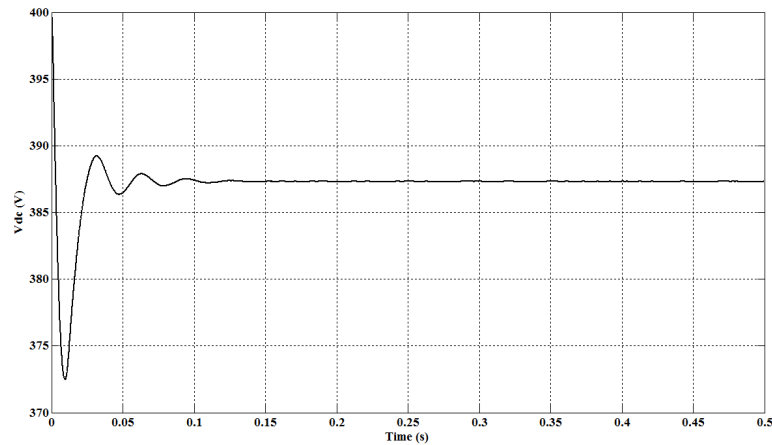

Figure 9: Capacitor voltage

## V. T.H.D ANALYSIS

In Figure 10 we shown that Total Harmonic Distortion (THD) of Source current without DSTATCOM is found 17.04 %.

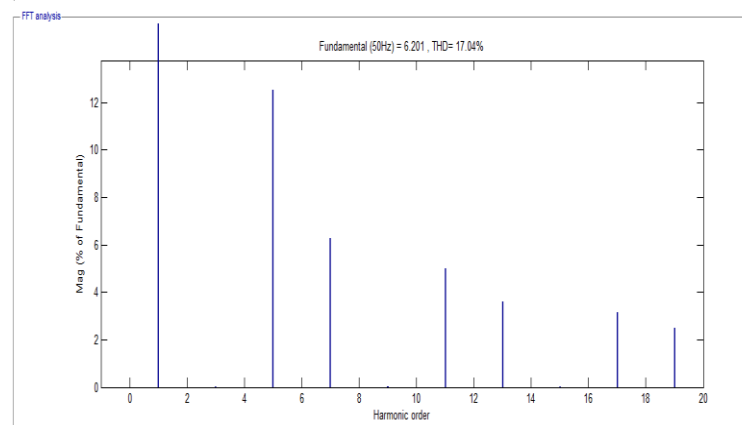

Figure 10: T.H.D without DSTATCOM

Total harmonic distortion (THD) of source current is found 4.92% Shown in figure 11. It shows the functions of DSTATCOM and its control algorithm for harmonic compensation and reactive power compensation.

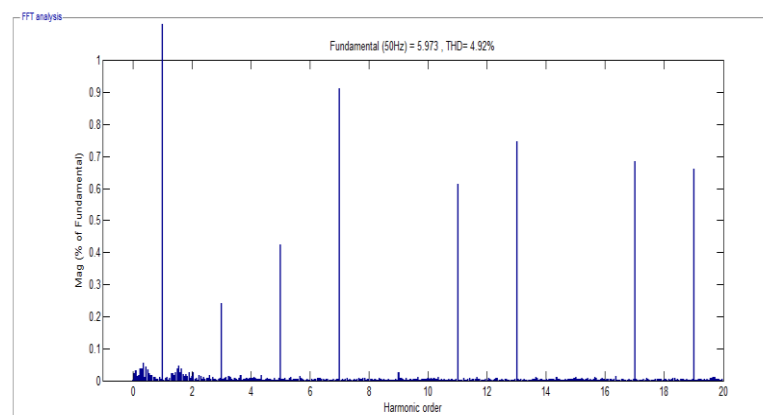

Figure 11: T.H.D with DSTATCOM



## VI. CONCLUSION

A DSTATCOM has been implemented with the SMC with PI control algorithm for mitigating the power quality problems and it has enhanced the active power capability. The SMC has been verified for the dynamics in the DC-link voltage and found robust and acceptably fast to avoid large variations in DC-link voltage. Moreover, from the experimental results it has been inferred that the sliding mode control with PI controller algorithm has been found capable of meeting various functionalities of DSTATCOM such as source currents balancing, harmonics mitigation, and reactive power compensation.

## REFERENCES

- [1] Valluri Chandra sekhar, Krishan Kant, Bhim singh. 'DSTATCOM supported induction generator for improving power quality.' IET-2016, vol. 10, iss 4, pp. 495-503
- [2] Singh, B., Solanki, J.: 'A comparison of control algorithms for DSTATCOM', IEEE Trans. Ind. Electron., 2009, 56, (7), pp. 2738–2745
- [3] Singh, B., Kant, K., Arya, S.: 'Notch filter based fundamental frequency component extraction to control DSTATCOM for mitigating current related power quality problems', IET Power Electron. 2015
- [4] Arya, S., Niwas, R., Kant, K., et al.: 'Power quality improvement in isolated distributed generating system using DSTATCOM', IEEE Trans. on Industry Applications, Early Access, 2015
- [5] Saetio, S., Devaraj, R., Torrey, D.A.: 'The design and implementation of a three-phase active power filter based on sliding mode control', IEEE Trans. Ind. Appl., 1995, 31, (5), pp. 993–1000
- [6] Ankush Sharma, 'Review Paper on Applications of D-Statcom in Distribution System' International Journal of Science and Modern Engineering, ISSN: 2319-6386, Volume-2, Issue-11, October 2014
- [7] Ghosh, A., Ledwich, G.: 'Power quality enhancement using custom power devices' (Springer International Edition, Delhi, 2009)
- [8] Eldery, M.A., El-Saadany, E.F., Salama, M.M.A.: 'Sliding mode controller for pulse width modulation based DSTATCOM'. Proc. of CCECE, 2006, pp. 2216–2219
- [9] Bandal, V.S., Madurwar, P.N.: 'Performance analysis of shunt active power filter using sliding mode control strategies'. 12th Int. Workshop Variable Structure Systems (VSS), 2012, pp. 214–219
- [10] Singh, B., Al-Haddad, K., Chandra, A.: 'Active power filter with sliding mode control', IEE Proc. Gener. Transm. Distrib. 1997, 144, (6), pp. 564–568
- [11] Errabelli, R.R., Kolhatkar, Y.Y., Das, S.P.: 'Experimental investigation of sliding mode control of inverter for custom power applications'. IEEE Power Engineering Society General Meeting, 2006, pp. 8–16
- [12] Teodorescu, M., Stanciu, D., Radoi, C., et al.: 'Implementation of a three-phase active power filter with sliding mode control'. Proc. of IEEE Int. Conf. on Automation Quality and Testing Robotics (AQTR), 2012, pp. 9–13
- [13] Mendalek, N., Al-Haddad, K., Kanaan, H.Y., et al.: 'Sliding mode control of three-phase four-leg shunt active power filter'. Proc. of IEEE Power Electronics Specialists Conf., PESC, 2008, pp. 4362–4367